



KlevaKlip Adjustable Joist Support

(For building decks over concrete)

Play Installation DVD at www.klevaklip.com.au

Installation Steps for AJH45G Adjustable Joist Support

Note: Each Adjustable Joist Support (joist holder + base plate) requires (Galvanised) 2 x M10 Hex Head Bolts, 4 x M10 Nuts, 2 X M10 washers & 1 x 12mm Galvanised Dynabolt or 10mm Masonry Bolt or similar.

Step 1 - Positioning Joist Support Base Plates

Mark out positions for the base plates on the concrete slab (see table for minimum span requirements for 90mm and 70mm joists) These are all based upon "continuous span" with joists at 450mm between centers. Either use a "straight edge" or run a string line from one of the notches in the outer base plates and flick the line for the positions of the internal base plates.

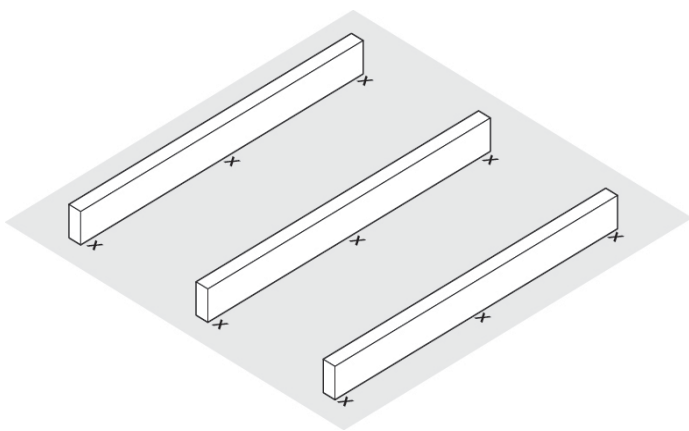

Step 2 - Drill Holes for Base Plates

Drill holes for base plates (or for joist Supports if securing them directly to concrete) using 12mm or 10mm masonry bit.

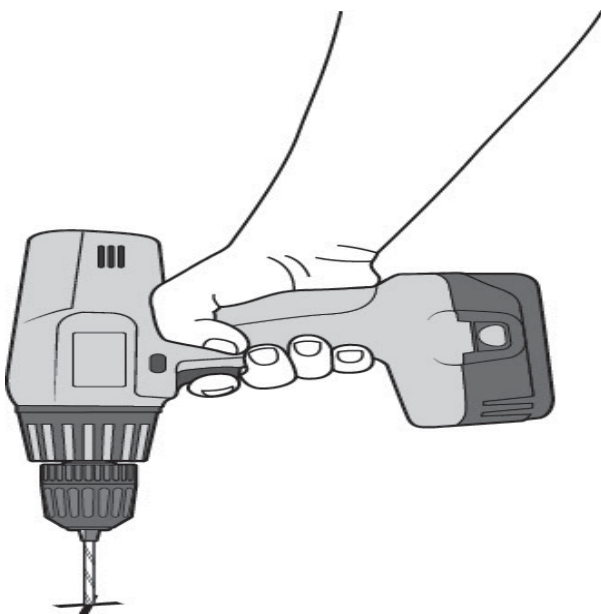

Step 3 - Inserting M10 Hex Head bolt

Insert 2 x 10mm hex-bolt through base plate. Note: The KlevaKlip Adjustable Joist Support system is designed to provide a "top of the joist" height from 80mm (using 60mm length bolts + 70mm x 45mm joists) to 170mm (using 120mm length bolts + 90mm x 45mm joists).

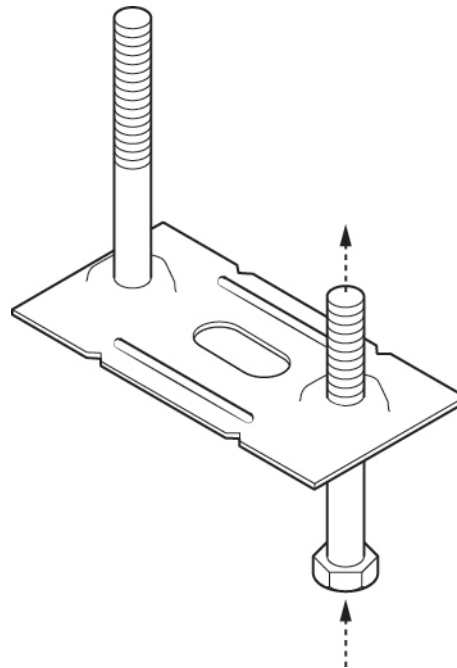

Step 4 - Fixing Base Plate

Fix base plate to concrete using 12mm Galvanised DynaBolts or 10mm masonry bolts or similar.

Repeat steps 1 - 4 for all base-plates to be installed.

Tip No. 1 before fully tightening DynaBolts, either use a straight edge or run a string line along the edge of the base-plate vertical bolts to ensure they line up correctly. Adjust base-plate in the slot if required.

Tip No. 2 Check all base-plates are "square" to the above-mentioned straight edge or stringline

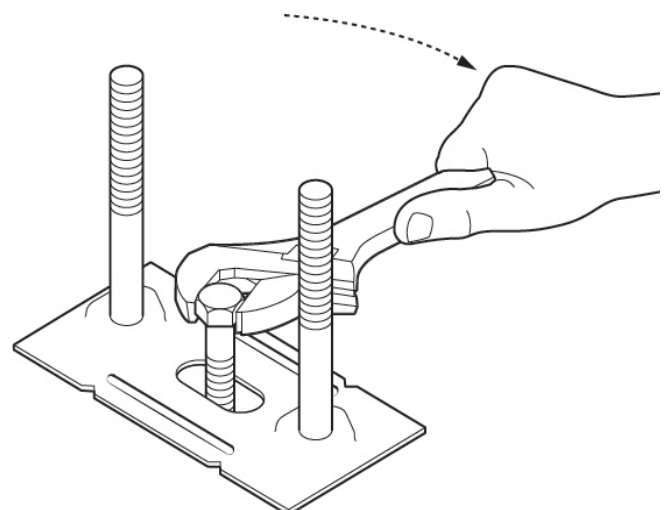

Step 5 - Attach Joist Support

Attach joist Support onto hex bolts and adjust to approx height required. Semi-tighten nuts – this will tighten the whole structure enough to withstand joists being inserted and secured.

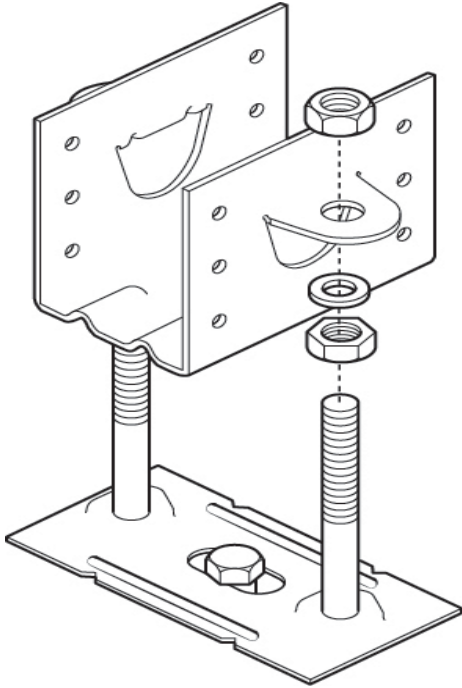

Step 6 - Insert Joist into Support

Insert joist into joist Support and secure with minimum 2 of 3.2mm x 30mm connector nails or 8g x 30mm stitching screws on each side of the joist Support.

Tip: – when fixing nails, brace the other side of the joist Support with your foot to minimise vibration

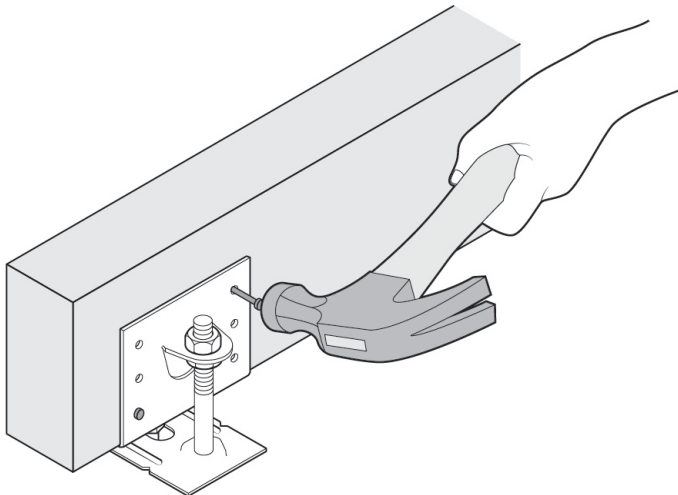

Step 7 - Joist Adjustment

Adjust joist to correct height using dumpy or laser-level or string line. (Note – you will need to loosen the nuts off if the joist Support height needs adjusting)

Fully tighten nuts locking the joist Supports.

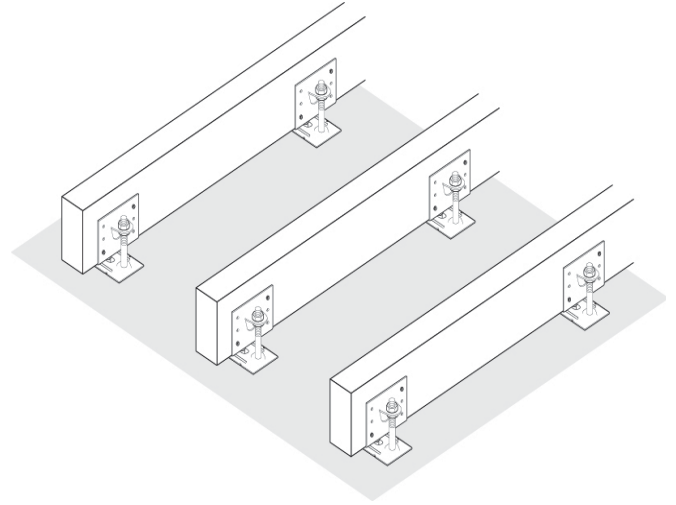

Load Bearing:

The KlevaKlip Adjustable Joist Support system has been independently tested to support a load bearing capacity of 350 kg per square metre when used at the recommended joist spans listed below.

Corrosion Protection:

KlevaKlip Joist Supports and Base Plates have been hot dip galvanised in accordance with Australian Standards AS/NZS 4680:2006 (ISO 1461)

Span requirements for base-plate positioning

All based upon "continuous span" with joists at 450mm between centres.

	Recommended Span (mm)	Maximum Span (mm)
70 x 45mm MGP10	800	1200
90 x 45mm MGP10	1000	1500
*120 x 45mm MGP10	1200	1800
*140 x 45mm MGP10	1200	1800

* Joist span limited by lateral loading on bolts

What Length Bolts do you require?

Note: All measurements based on using Galvanised Zenith brand long-threaded Bolts.

Hex Head Bolt Length	Min Height to Bottom of Joist	Max Height to Bottom of Joist	Min Height to Top of 70/90mm Joist	Max Height to Top of 70/90/140mm Joist
60mm	16mm	20mm	86 / 106mm	90 /110/160mm
120mm	18mm*	80mm	88 / 108mm*	150 /170/220mm
**No Bolt	6mm		76/ 96mm	

* If using long bolts at low heights, to prevent the bolts protruding past the top of joist, the end of the bolt will need to be cut off.

** When Using Joist Support Only.